

DISTRIBUIDOR AUTORIZADO.

www.imservo.com

ventas1@imservo.com / ventas2@imservo.com

QUITO-GUAYAQUIL

ECUADOR



XINJE

XC3-19AR-E Module

Operating Manual

WUXI XINJE ELECTRIC CO., LTD.

Catalog

CHAPTER 1 BRIEF INTRODUCTION OF THE FUNCTIONS.....	3
CHAPTER 2 PROGRAM AND APPLICATION	7

Chapter 1 Brief Introduction of the Functions

1. Basic Performance

- Integrate logic Control, analog input/output in one body
 Digital Input: 9 points (NPN type optical coupling insulation)
 Digital Output: 10 points (Relay Type)
 Analog Input: 8 points (0~10 voltage)
 Analog Output: 2 points (0~10 voltage or 4~20mA)
- Support 3 channels AB phase input
- Support 4 channels high speed count (10KHZ)
- Simple structure
- High performance-price ratio, save the space greatly.

2. General Specification

• Electric Specification

Input Voltage	AC100V~240V
Voltage Allow Bound	AC90V~265V
Rated Frequency	50/60Hz
Power Consumption	Lower than 12W (TYP2.0W)
Allow Momentary Power-off	Lower than 20ms
Power for sensor use	24VDC±10% Maximum 400mA
Voltage Endurance	AC1000V-10MA 1 minute (between signal and earth)
Insulated Resistance	DC500V- about 10MΩ (between signal and earth)

• Ambient Condition

Operating temperature	0~50°C
Storage temperature	-10~60°C
Ambient temperature	20~85% (no dew)
Vibration Endurance	10~25Hz (X,Y,Z direction each 30 minutes 2G)
Anti-interfere	Voltage noise: 1000Vp-p
Ambient Air	No corrosive air
Protect Structure	Fit for IP65F



Please use the power cable thicker than 2mm² to prevent voltage decrease.
Even power off within 20ms, PLC can keep on working. If long time power off or abnormal voltage decrease, PLC will stop working, output will appear OFF status, when power recovers on, PLC will automatic run.

1-3. Input/Output Specification

- **Digital input/output**

Input 9 points: X0~X10

Output 10 points: Y0~Y11

Input Specification

Input signal voltage	DC24V±10%
Input signal current	7mA/DC24V
Input ON current	Up to 4.5mA
Input OFF current	Below 1.5mA
Input response time	About 10ms
Input signal form	Contact input or NPN open collector transistor
Circuit Insulation	Optical coupling insulation
Input action display	LED lights when input is ON

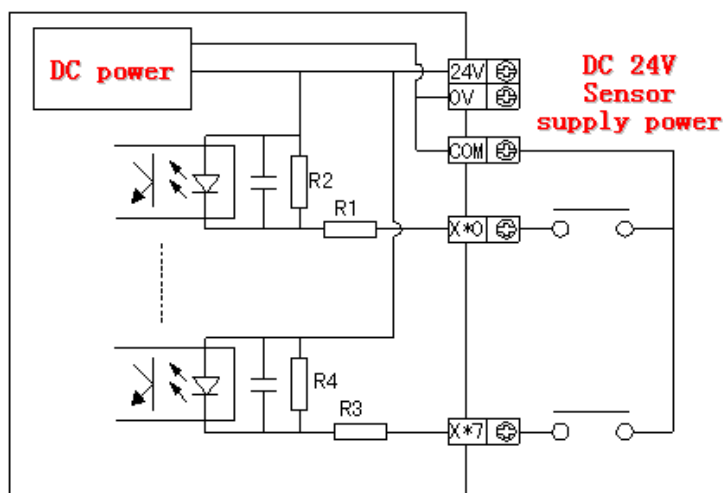

Output Specification

External Power		Below AC250V, DC30V
Circuit Insulation		Mechanic insulation
Action Indication		LED indicate lamp
Maximum Load	Resistor load	3A
	Inductance load	80VA
	Lamp load	100W
Minimum Load		DC5V 2mA
Response time	OFF→ON	10ms
	ON→OFF	10ms

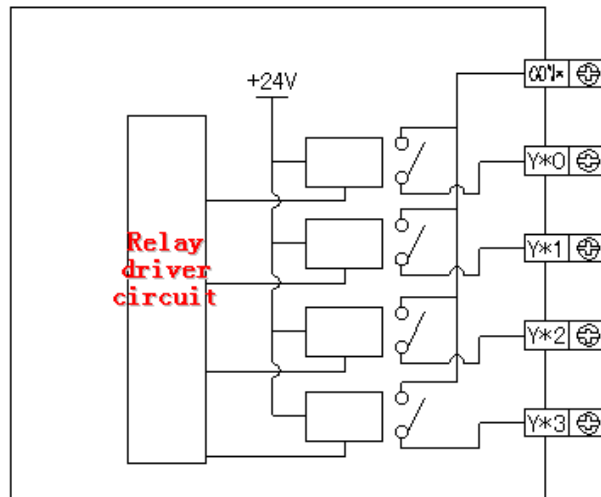

- **Pulse output**

XC3-19AR-E has one channel of high speed pulse output Y0, the pulse frequency can up to 200KHz.

- **Analog input/output**

Analog input: 8 channels (0~10V voltage)

Analog output: 2 channels (0~10V voltage or 4~20mA)

Basic parameter table

ITEMS	Analog input (AD)	Analog output (DA)	
	Voltage input	Voltage output	Current output
Analog input bound	0~10V	-	
Maximum input bound	DC±18V	-	
Analog output bound	-	DC0~10V (External load resistor 2KΩ~1MΩ)	DC4~20mA (external load resistor is less than 500Ω)
Digital input bound	-	8 bits binary data (0~256)	
Digital output bound	12 bits binary data (0~4095)	-	
Distinguish ratio	1/4095(12Bit); the converted data is stored into PLC in the form of Hex. (12Bit)	1/256(8Bit); the converted data is stored into PLC in the form of Hex. (8Bit)	
Colligate precision	0.8%		
Convert speed	15ms/ channel	2ms/ channel	
Analog using power	DC24V±10%,100mA		
Installation Format	Can use M3 screws to fix or directly install on DIN46277 (width: 35mm) guild		
Shape and Size	139×110×93.3 (unit: cm)		

Table of analog quantity with correspond register

Analog input

Channel	Register
0CH	ID0
1CH	ID1
2CH	ID2
3CH	ID3
4CH	ID4
5CH	ID5
6CH	ID6
7CH	ID7

Analog output

Channel	Register
0CH	QD0
1CH	QD1

- High speed counter

XC3-19AR-E																		
	Increment										Pulse+Dir Input					AB Phase Mode		
	C60	C60	C60	C60	C60	C61	C61	C61	C61	C61	C62	C62	C62	C62	C62	C63	C63	C63
	0	2	4	6	8	0	2	4	6	8	0	2	4	6	8	0	2	4
Max.F	10K	10K	10K	10K							10K	10K				5K	5K	
4-times F																1	1/4	
Count Interrupt	√	√	√	√								√					√	
X000	U										U					A		
X001											Dir					B		
X002		U										U					A	
X003												Dir					B	
X004			U															
X005				U														

Chapter 2 Program and Application

Program Instructions

About PLC program, please refer to XC series PLC manual.

Program software: XCPpro edit tool.